



OERLIKON

TESTING MACHINE

BEVEL GEAR TECHNOLOGY – TESTING MACHINES



KLINGELBERG

Intelligent Solutions for Discerning Users

All around the world, manufacturers of gearwheels and gearboxes ensure their leading edge in gear machining with innovative solution concepts from Klingelberg.

The **Oerlikon Bevel Gear Technology** division makes economical, high-precision production of bevel gears a reality for users. All machines have been perfectly designed to work as a system family, enabling pre-machining and finishing of even the most complex gears.

Klingelberg offers the most advanced technology and the most efficient machines for each and every step in the process chain. The production process chain for bevel gears includes **tool preparation, cutting, measuring, hardening, grinding or lapping and testing**, among others. The powerful **KIMoS (Klingelberg Integrated Manufacturing of Spiral Bevel Gears)** design software and the **Closed Loop concept** ensure transparency and documented quality through the entire process chain.

Oerlikon bevel gear machines were developed with real-world applications in mind and meet the varying demands of a whole range of application industries. The target markets include the automotive industry, the commercial vehicle industry, the agricultural industry, shipbuilding, and aviation, as well as industrial gear unit manufacturing and plant engineering.

Klingelberg, as a leading system supplier, also offers high-performance tools, and with this complete system, meets every requirement for flexible, efficient production – for the smallest and the largest lot sizes.



OERLIKON T 60 bevel gear testing machine

Exceptional Concepts for Every Process Step in Gear Technology

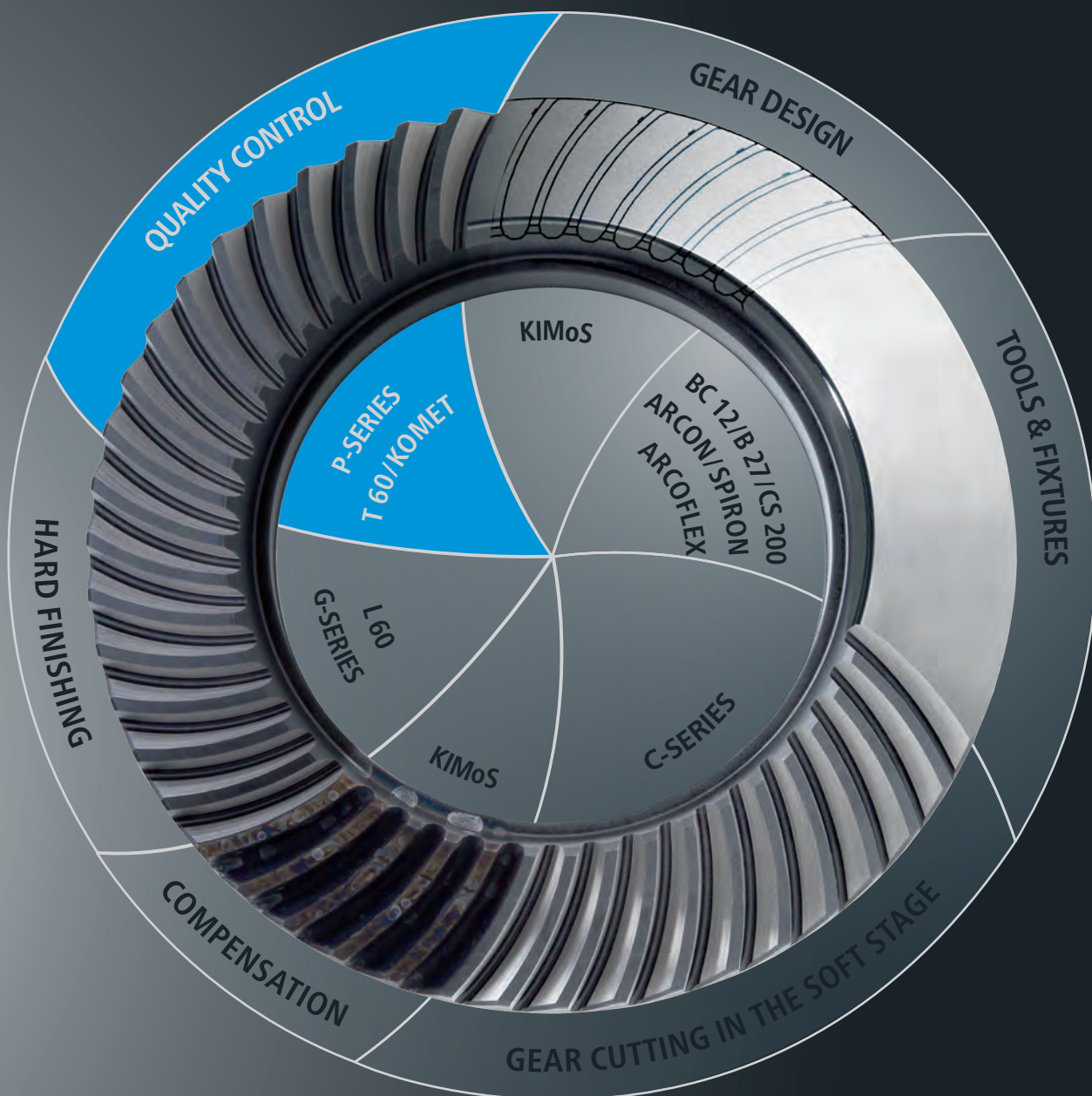

HIGHLIGHTS

Forward-looking Machine Designs with Cutting-Edge Technology

Oerlikon bevel gear testing machines are designed to allow all operational tasks, as well as loading and unloading, to be carried out from the front of the machine. The result is a completely new configuration of machines on the factory floor.

The intelligent machine design allows for a minimized, active space requirement. The passive floor space has also been designed to enable a tighter layout of individual machines on the factory floor. As a result, non-productive areas and walkways for the operating staff can be considerably reduced.

The T 60 bevel gear testing machine is a CNC testing machine with three linear axes for fully automatic hard and soft testing of spiral bevel and hypoid bevel gear sets with a 90° shaft angle. Shaft angles from 79° to 101° are optionally available. The T 60 offers a wide range of objective and subjective testing options, with rotational speeds of up to 3,250 rpm and maximum brake torque of 95 Nm.



OERLIKON T 60 bevel gear testing machine



Operator-friendly, Easy-to-service Machine Design

- All operational tasks—such as loading, unloading, and retooling—can be performed from the front
- Wide-opening working chamber provides easy accessibility for retooling and manual loading
- Intuitive user software prevents improper operation
- Optional foot switch to clamp and release workpieces
- Efficient maintenance thanks to easy accessibility
- No hydraulics
- Easy-to-read pneumatics layout on a central panel

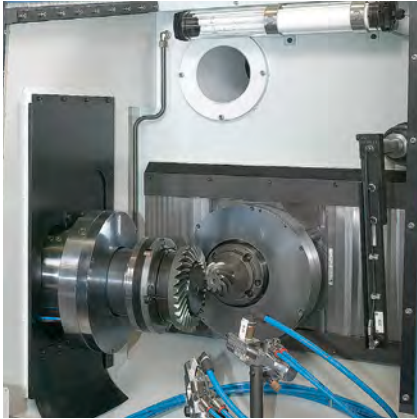

Forward-looking Machine Design with Maximum Testing Reliability

- Compact, automation-capable machine design
- Immediately useful measuring results thanks to short test times and automatic logging of measuring results
- Structured data archiving ensures traceability of measurements
- Can be used for both production and development of bevel gears
- Broad-scope tailoring of measurements to suit customer requirements



Universal Bevel Gear Testing Machine for Various Measurement Methods

- Separate evaluation of concentricity errors for pinion and ring gear with double-flank test
- Testing of contact pattern position, form, and size
- Testing of running properties by single flank test and/or structure-borne noise measurement in conjunction with load, rotation speed, or mounting position
- Automatic determination of optimal mounting position through incremental testing of various mounting positions and/or continuous measurement of a single mounting position range (optional)



Efficient and Reliable Production

- Extremely small space requirement thanks to compact machine design and access options designed for easy operation and maintenance
- Efficient clamping device change using quick-release system
- Suitable for automatic loading
- Automatic evaluation and documentation of test results

HIGHLIGHTS

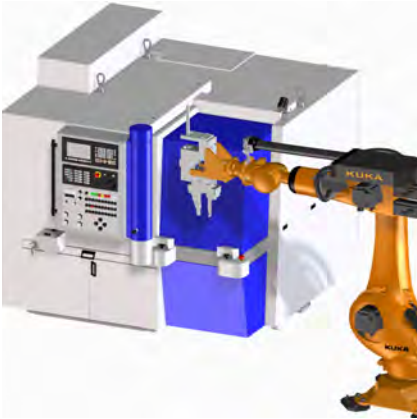

Intelligent Automation Concepts for Maximum Productivity

- Interface provided for handling systems (robot loading or gantry loading) and automatic loading and unloading of the tester enables maximum productivity and production feasibility
- Integration in fully automated production lines for optimal workflow
- Machine fixing elements for precise positioning and mechanical attachment of the machine

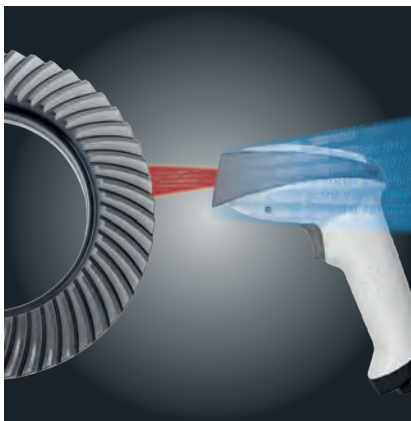

A Range of Interfaces for Various Production Steps

- Marking system: data transfer, for engraving mounting distance variations on the gear set
- Operating data acquisition: one standard interface that can be configured individually according to the hardware, log and data volume
- Scanner: reading of part designation/serial number to ensure parts traceability

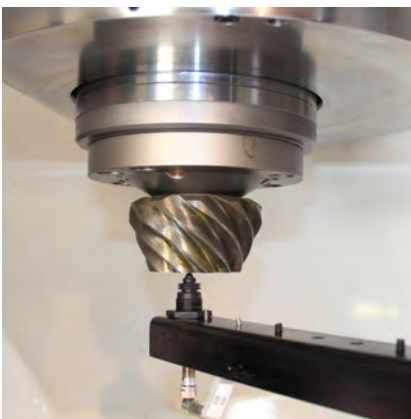

Numerous Add-on Options for the Tester

- Rotational error measurement and structure-borne noise measurement via speed scan
- Counter support for clamping pre-mounted ring gears. Mechanical extra equipment including software to support the pre-mounted ring gear
- Face checking device for determining basic dimension (mounting distance minus pinion addendum)
- Gearstat software: measuring result filter program for long-term production monitoring

Optimal Running Behavior Thanks to Automatic Setting of Best-possible Mounting Position

Automatic optimum pinion mounting distance (best fit) search in which the pinion mounting distance is changed continually during the measurement. This measurement type can take place using a single-flank working test or structure-borne noise analysis. The results are shown in the measurement report as well as the normal view of the T 60-PC software.

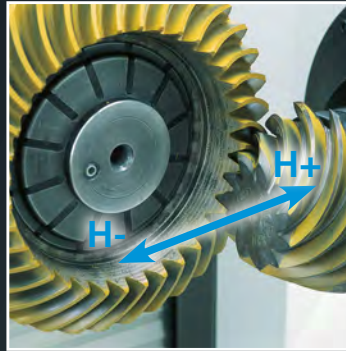

Gear set in nominal position

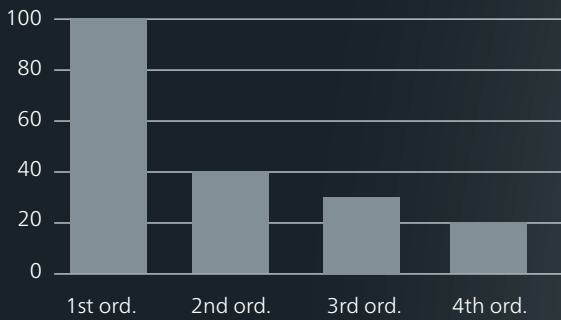

Poor running behavior

Gear set in best position

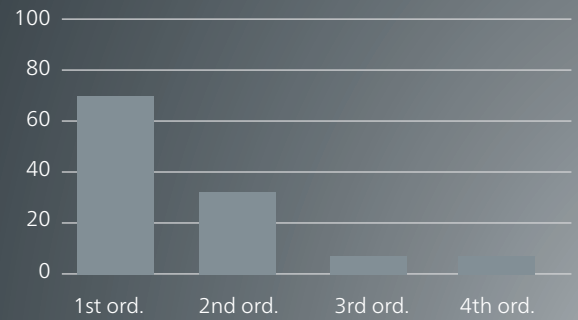

Good running behavior

Mesh1

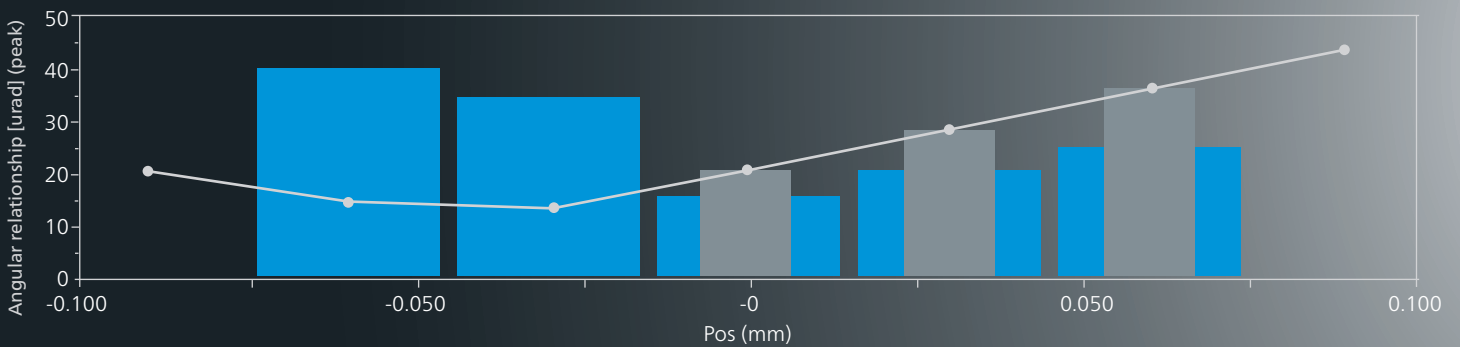

Tolerances

Upper limit violations

• Interpolation + smoothing

Amplitude of first tooth mesh order (Mesh1) across a possible extent of the pinion mounting distance.

Best Position (BP):	All positions are measured and those with the best running behavior are output as BP.
Best Position, all measuring positions (MP) in tolerance:	All positions are measured and must fall within tolerance.
Tolerances:	During continuous measurement, different tolerances can be defined for each position approached.

Drive Components with Guaranteed Quality Provide Optimal Performance

In countless industries, Klingelberg solutions have become a staple on the international market. To meet market requirements for high productivity in mass production and ensure flexibility in small-batch production, Klingelberg offers a range of solution concepts for just about any requirement.

Used throughout the world, the [Simplified with Passion](#) system plays an important part in ensuring that machine tasks are made simple. Moreover, the Klingelberg system contributes to standardization and quality assurance on a global scale.



Automotive



In cars, spiral bevel gears are used in all-wheel-drive systems and rear-wheel-drive systems to transmit torque from the transmission "to the road". Due to increasing performance requirements, these drives must transmit outputs of over 300 kW in some cases. The bevel gears they use must be efficient, smooth-running, and low-maintenance. Reproducible quality in series production with the fastest possible production times are key requirements in this industry.

Commercial Vehicles



Commercial vehicles are always rear-wheel-driven. The bevel gear sets they use must transmit power in the 550 kW range – at extremely high torques. This places high demands on durability and strength. The bevel gear sets must be efficient, robust and low-maintenance. Use of the integrated Klingelberg system makes it possible to mass-produce bevel gears with the quality required.

Agriculture



In agricultural applications such as tractors, spiral bevel gears are built into the rear axles, as well as the front axles in certain cases. Harvesters and hay machines use straight bevel gears to enable the corresponding functions. Whereas the bevel gear set in a tractor rear axle drive must transmit up to 400 kW, the loads on straight bevel gears are comparably low. The most important market requirement for straight bevel gears is a modern, cost-efficient production solution.

Industrial Gear Units



The industrial gear unit sector comprises many different applications, all of which place great demands on the reliability of the drive components. The bevel gears for these sectors are often manufactured by companies that are specialized in small batch sizes and a wide variety of components. A rigid machine design as well as flexible and cost-effective tool systems are the key to success in order to be a market leader here.

Aviation



Bevel gears used in airplanes must meet the highest quality grades in terms of pitch and concentricity (DIN 1–3) and must also execute rotary motions with absolute reliability. Just as important are other geometrical features such as surface finish, tooth root geometry, rotational error, high strength, and low weight. Frequently used in this industry are specialty materials, which place extreme demands on tools and processes.

Railway Gears



The railway industry is deeply rooted in the industrial landscape. In this industry as elsewhere, growing environmental and climate protection demands are setting the pace: Although rail transport already has a good environmental and climatic report card per se, companies in the industry are already investing in research and development in order to be prepared for the increasing demands of the future. In addition to lightweight design of rail motor units, they focus their efforts on developing components and drive systems with even lower emissions and greater energy efficiency.

TECHNICAL DATA

RANGE OF APPLICATION	T 60 Standard	T 60 Option
Workpiece diameter (max.)	Ø 500 mm	Ø 600 mm (only with standard 90°)
Y (H) axis distance: ring gear spindle front to pinion spindle	150 – 350 mm	200 – 400 mm
Z (J) axis distance: pinion spindle front to ring gear spindle	120 – 340 mm	
Hypoid adjustment in X (V) axis	± 70 mm	
Shaft angle	90°	79° – 101°
Pinion headstock		
Speed range, infinitely	0 – 3,250 rpm	
Torque (max.), at n = 0 – 1240 rpm	57 Nm	
Torque (max.), at n = 1240 – 3250 rpm	57 – 21 Nm	
Inner taper	Taper #39	Taper #50
Reduction sleeve	-	Taper #50 to #39
Pull-in force for workpiece clamping device (max.)	23,000 N	
Ring gear headstock		
Speed range, infinitely	0 – 3,000 rpm	
Torque (max.), at n = 0 – 750 rpm	93 Nm	
Torque (max.), at n = 750 – 3000 rpm	93 – 24 Nm	
Inner taper	Taper #39	-
Reduction sleeve	-	Taper #39 to #14
Pull-in force for workpiece clamping device (max.)	23,000 N	
Machine dimensions with Elbaron (oil mist collector) (L x W x H), approx.	2,350 x 2,240 x 2,500 mm	

The above-mentioned maximum values were determined for industry-typical transmissions. Further testing may be required to determine whether maximum values can be combined.

Installation Dimensions

T 60: FRONT VIEW

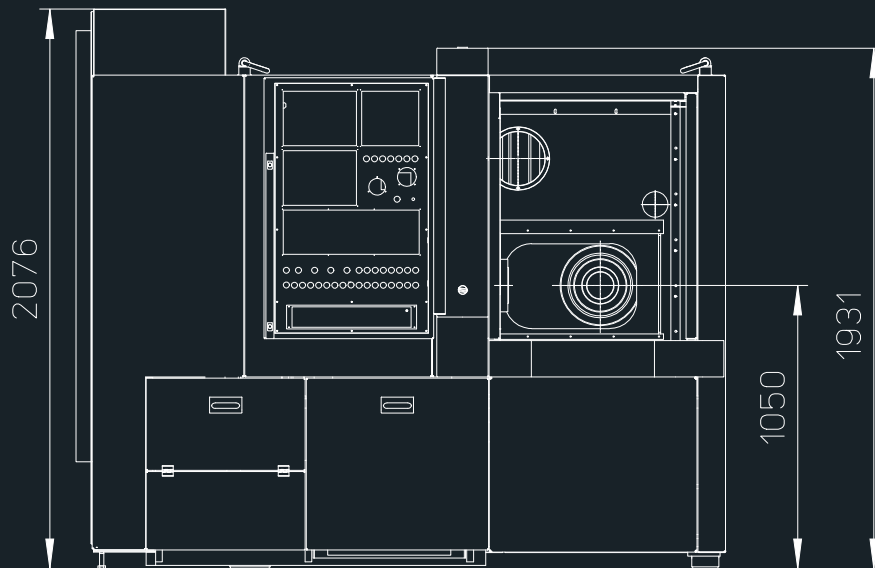

T 60: TOP VIEW

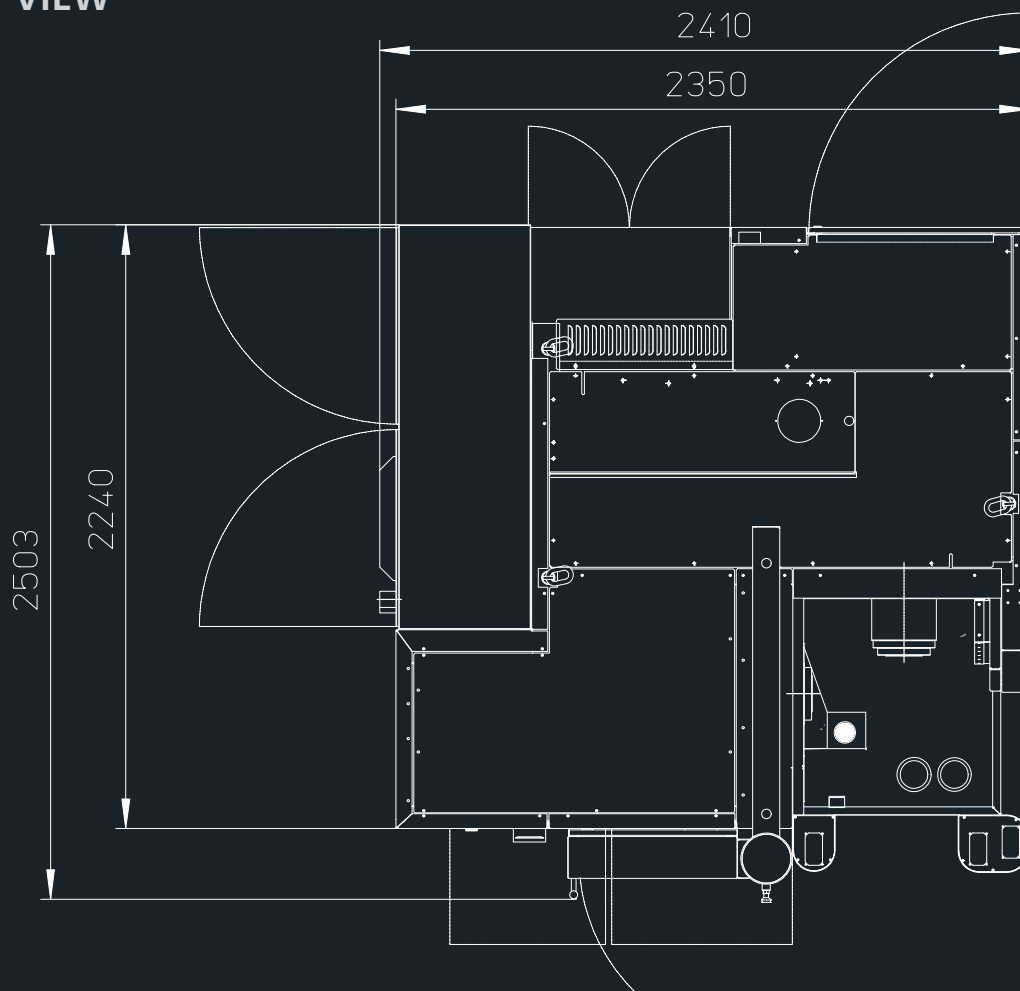

All specifications in mm

KLINGELNBERG Service

The KLINGELNBERG Group is a world leader in the development and manufacture of machines for bevel gear and cylindrical gear production, and precision measuring centers for gearing and axially symmetrical components, as well as the production of customized high-precision drive components. In addition to the headquarters in Zurich, Switzerland, further development and production facilities are located in Hückeswagen and Ettlingen, Germany.

The company also maintains a presence with Sales and Service offices and numerous marketing agents. On this basis, Klingelberg offers users a comprehensive range of services for all aspects of toothed gear design, manufacturing, and quality inspection. The spectrum includes technical consulting, on-site machine acceptance, operator and software training as well as maintenance contracts.

KLINGELNBERG Solutions

Klingelberg solutions are used in the automotive, commercial vehicle, and aviation industries, as well as in shipbuilding, the wind power industry, and the general transmission manufacturing industry. With numerous R&D engineers around the globe and over 200 registered patents, the company consistently demonstrates its capacity for innovation.

EN 12/2020 - Subject to technical modifications without notice.

FOLLOW US AND STAY UP TO DATE:



KLINGELNBERG AG

Binzmühlestrasse 171
8050 Zürich, Switzerland
Fon: +41 44 278 7979
Fax: +41 44 273 1594

KLINGELNBERG GmbH

Peterstraße 45
42499 Hückeswagen, Germany
Fon: +49 2192 81-0
Fax: +49 2192 81-200

KLINGELNBERG GmbH

Industriestraße 5-9
76275 Ettlingen, Germany
Fon: +49 7243 599-0
Fax: +49 7243 599-165

You can also find your local contact for sales advice at www.klingelberg.com/kontakt